

ELEVATION OF PREPARED
OPENING VIEWED FROM INSIDE

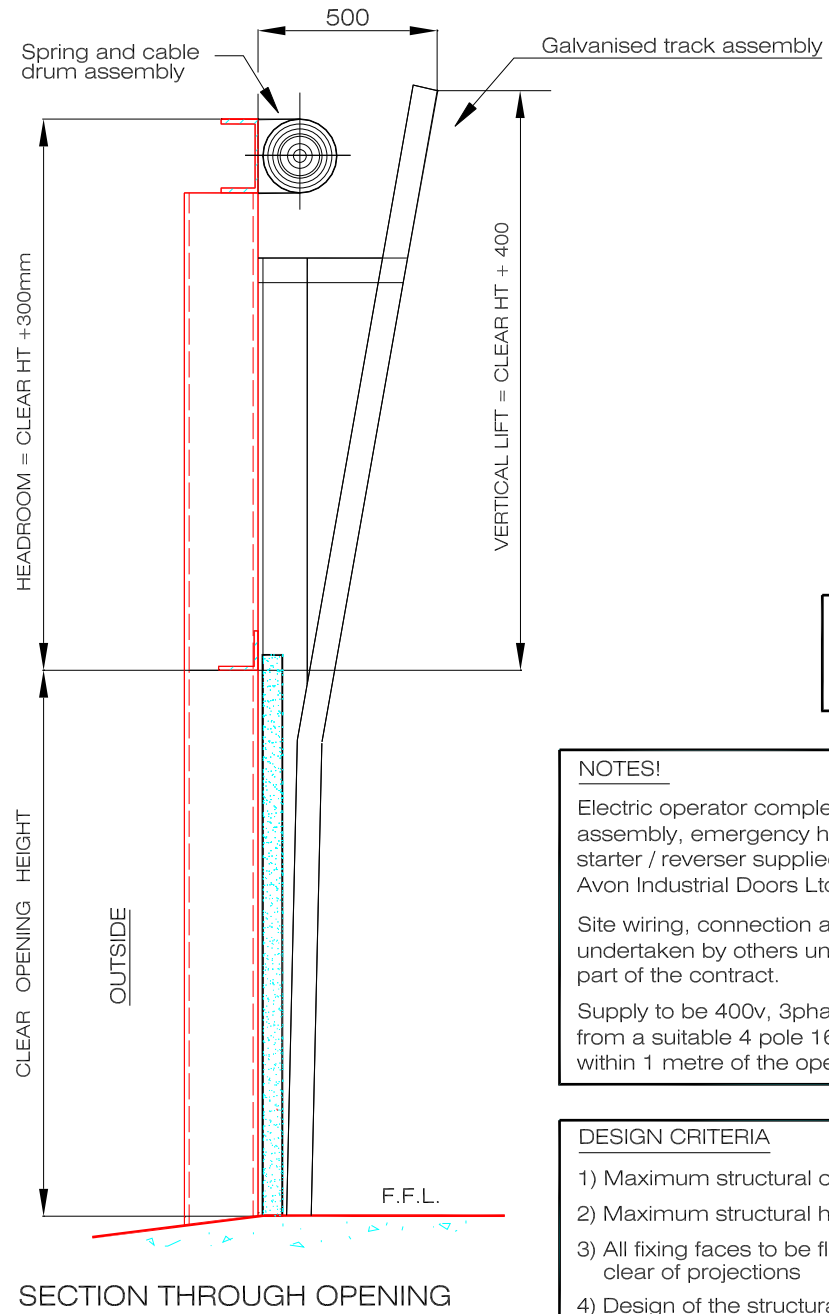
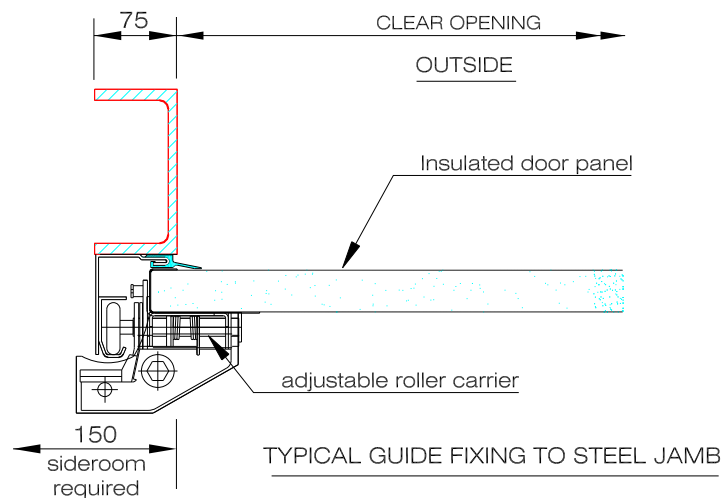

FULL VERTICAL LIFT
ARRANGEMENT

NOTES!

Electric operator complete with integral limitswitch assembly, emergency handchain operation and starter / reverser supplied and fitted by Avon Industrial Doors Ltd

Site wiring, connection and commissioning to be undertaken by others unless previously agreed as part of the contract.

Supply to be 400v, 3phase, 50Hz plus neutral from a suitable 4 pole 16 amp isolator sited within 1 metre of the opening on the motor side

DESIGN CRITERIA

- 1) Maximum structural opening width 7500 mm
- 2) Maximum structural height 6000mm
- 3) All fixing faces to be flush, plumb clear of projections
- 4) Design of the structural frame to be suitable to support the door and its fixings based on a design weight of 24 Kg / sq M.

THIS DRAWING MUST NOT BE SCALED.