

ELEVATION OF PREPARED
OPENING VIEWED FROM INSIDE

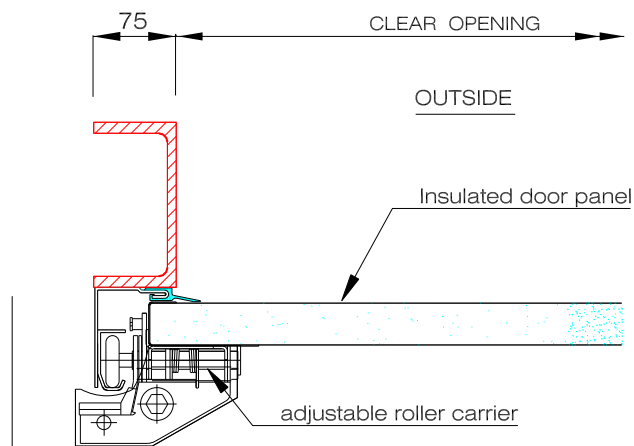

TYPICAL GUIDE FIXING TO STEEL JAMB

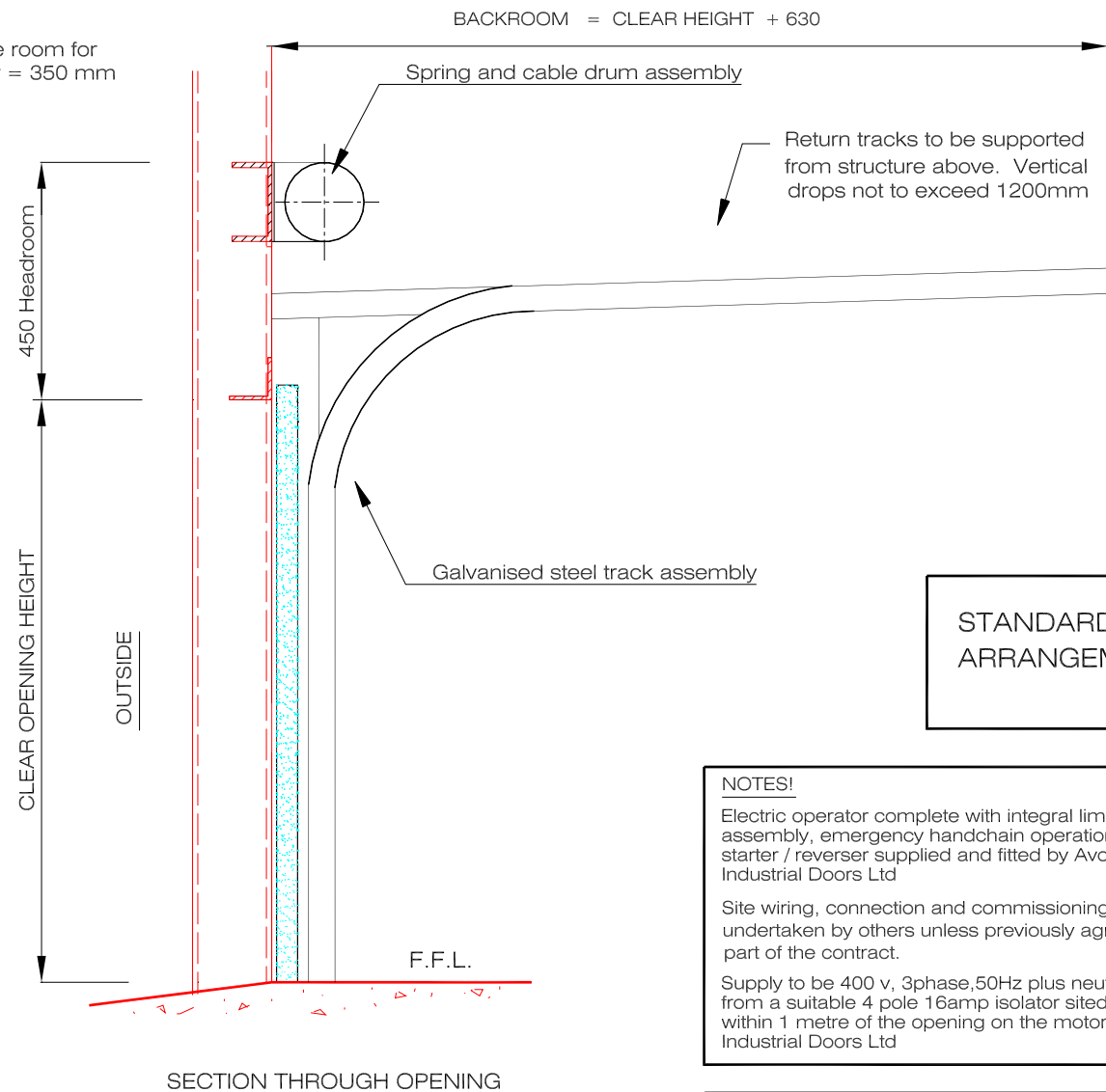

SECTION THROUGH OPENING

**STANDARD LIFT
ARRANGEMENT**

NOTES!
 Electric operator complete with integral limit switch assembly, emergency handchain operation and starter / reverser supplied and fitted by Avon Industrial Doors Ltd
 Site wiring, connection and commissioning to be undertaken by others unless previously agreed as part of the contract.
 Supply to be 400 v, 3phase, 50Hz plus neutral, from a suitable 4 pole 16amp isolator sited within 1 metre of the opening on the motor side. Industrial Doors Ltd

DESIGN CRITERIA
 1) Maximum structural opening width 7500 mm
 2) Maximum structural height 6000mm
 3) All fixing faces to be flush, plumb and clear of projections.
 4) Design of the structural frame to be suitable to support the door and its fixings based on a design weight of 24 Kg / sq M.

THIS DRAWING MUST NOT BE SCALED.